

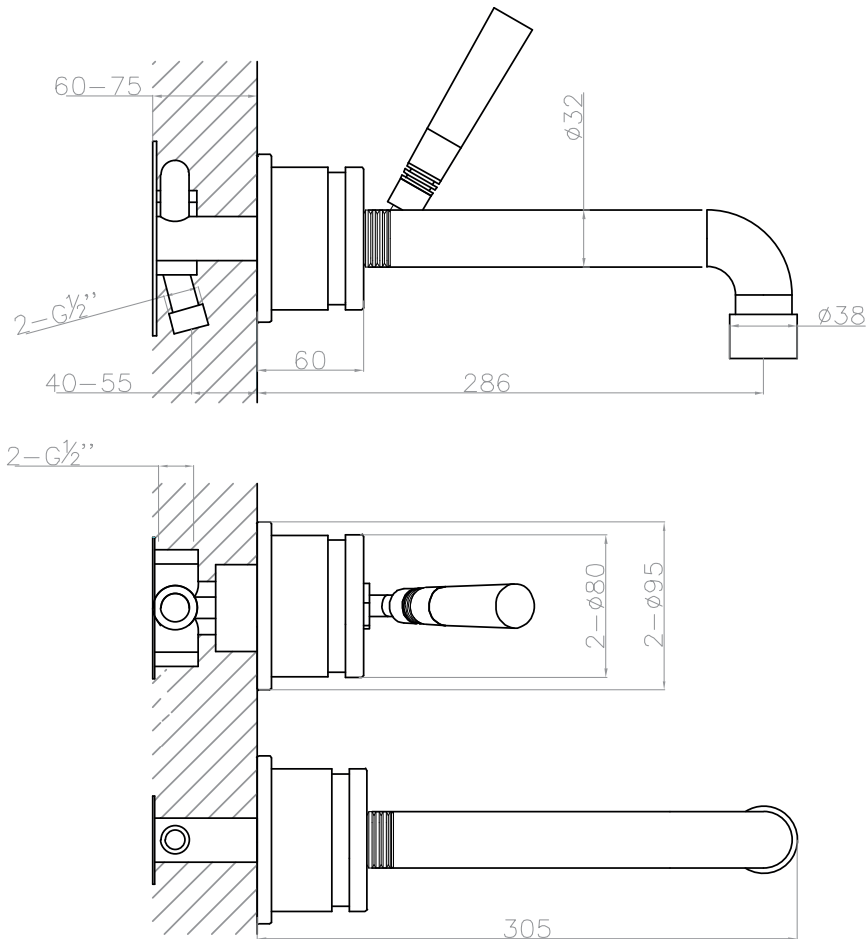

JEE-O soho wall basin mixer specifications

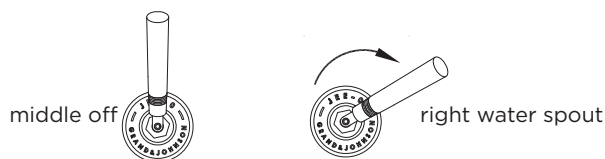

Note:
UV radiation and extreme temperature can affect the color and structure of the JEE-O soho basin wall surface.



Article code:

700-1500

● Brushed stainless steel - **RAW**

700-1502

● Hammercoated black matt

700-1508 green RAL 6003

● Powder coating matt

700-1509 grey RAL 7040

● Powder coating matt

Material:

Stainless Steel r304

Coating:

1.5 Electro powder spray

Cartridge:

Sedal ceramic mixing mechanism (progressive),
item code **005-0104**

Cleaning:

cleaning vinegar or alcohol

Flow at water of 38°C / 100,4°F:

10l / 2,6gal p/m at 3bar pressure

Connection:

Thread:

4 x G 1/2" (ø15mm / 0.6")
British Standard Pipe (BSP)

Dimension package:

Weight:

Package weight:

L 56 x W 34 x H 17 cm
4.4 kg
0.9 kg

2 year warranty

HS code:

Approvals:

84818011900

SLS BS EN 817, SS 375,
AS/NZS 4020, BS EN