

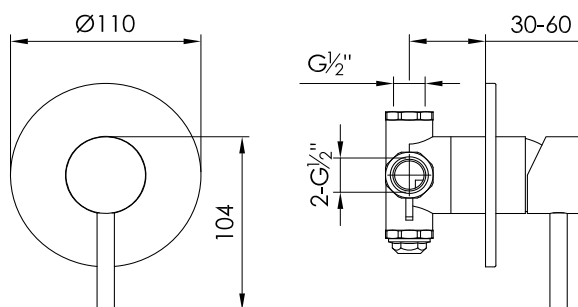

JEE-O slimline mixer 01 specifications



Note:
UV radiation and extreme temperature
can affect the color and structure of the
surface of the structured black version

Article code:

800-2100

● brushed stainless steel

800-2103

● structured black stainless steel

Material:

Stainless Steel r304

Cartridge:

Sedal ceramic mixing mechanism (40mm),
item code **005-0102**

Cleaning:

JEE-O protect

Connection:

Thread:

3 x G 1/2" (ø15mm / 0.6")
British Standard Pipe (BSP)

Dimension package:

Total weight:

Package weight:

L 23 x W 15 x H 16 cm
1.26 kg
0,27 kg

2 year warranty

HS code:

84818011900