

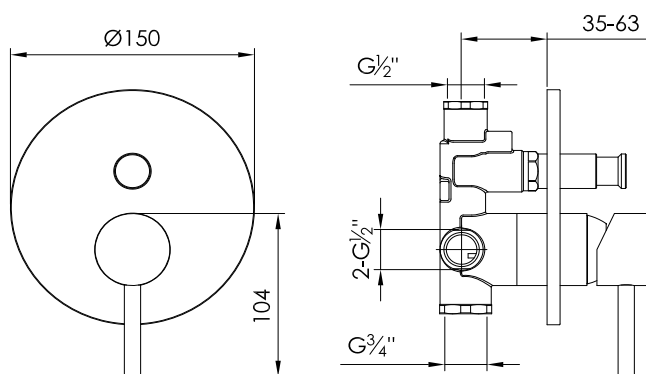

JEE-O slimline mixer O2 specifications



Note:
UV radiation and extreme temperature
can affect the color and structure of the
surface of the structured black version

Article code:	800-2200 ● brushed stainless steel 800-2203 ● structured black stainless steel	Connection:	1 x G 3/4" (ø19mm / 0.75") 3 x G 1/2" (ø15mm / 0.6") British Standard Pipe (BSP)
Material:	Stainless Steel r304	Thread:	
Cartridge:	Sedal ceramic mixing mechanism (40mm), item code 005-0102	Dimension package:	L 22 x W 18 x H 19 cm
Cleaning:	JEE-O protect	Total weight:	1.82 kg
		Package weight:	0.42 kg
		2 year warranty	
		HS code: 84818011900	