

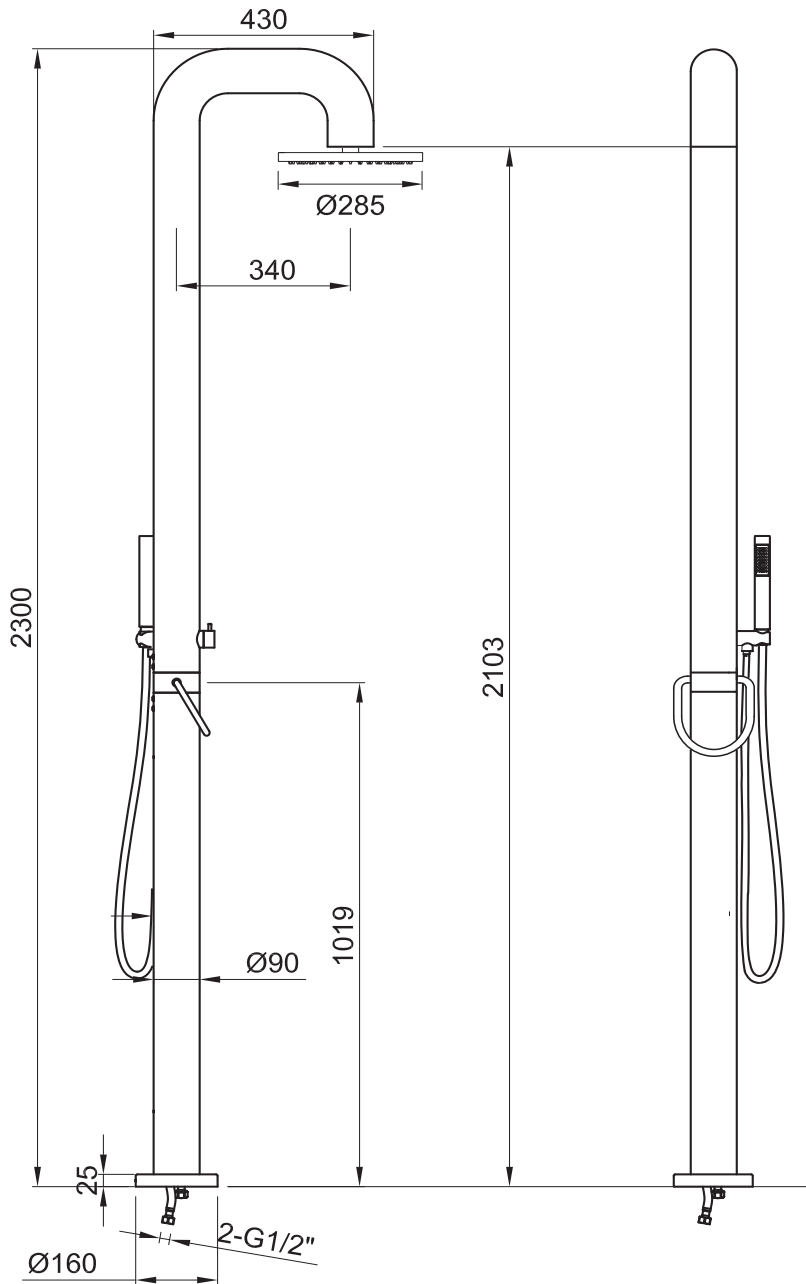

# JEE-O fatline shower 02 specifications

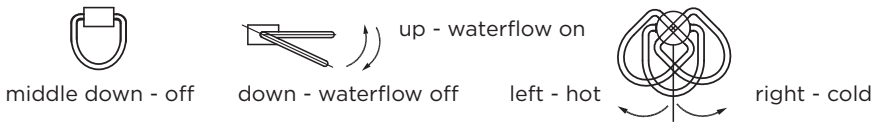

interchangeable showerhead ø85 mm included



Article code:	<b>100-6210</b> ● Brushed	Connection:	2 x G 1/2" (ø15mm / 0.6") nylon <sup>(out)</sup> /epdm <sup>(in)</sup> flexhose with stainless steel swivel British Standard Pipe (BSP)
Material:	Stainless Steel r316	Thread:	
Cartridges:	Kerox ceramic mixing mechanism (35mm), item code 005-0101 and JEE-O ceramic diverter mechanism, item code 005-0302	Dimension package:	L 161 x W 27 W 66 x H 24 cm
Interchangeable shower heads:	ø285mm/127 nozzles, item code 200-6140 ø85mm/ 78 nozzles, item code 200-6120	Total weight:	18,7 kg
Cleaning:	JEE-O protect	Package weight:	3,2 kg
Flow at water of 38°C /100,4°F:	12l p/m at 3bar pressure	Placing on a water-tight floor	
Flexhose:	150 cm length	2 year warranty	
		HS code:	84818011900
		Approvals:	SLS BS EN 817, SS 375, AS/NZS 4020, BS EN

